

# HC2025S SEAT



**HC2025S Seat**

## SEAT RANGE



**HC2025S Seat (with arms rests)**

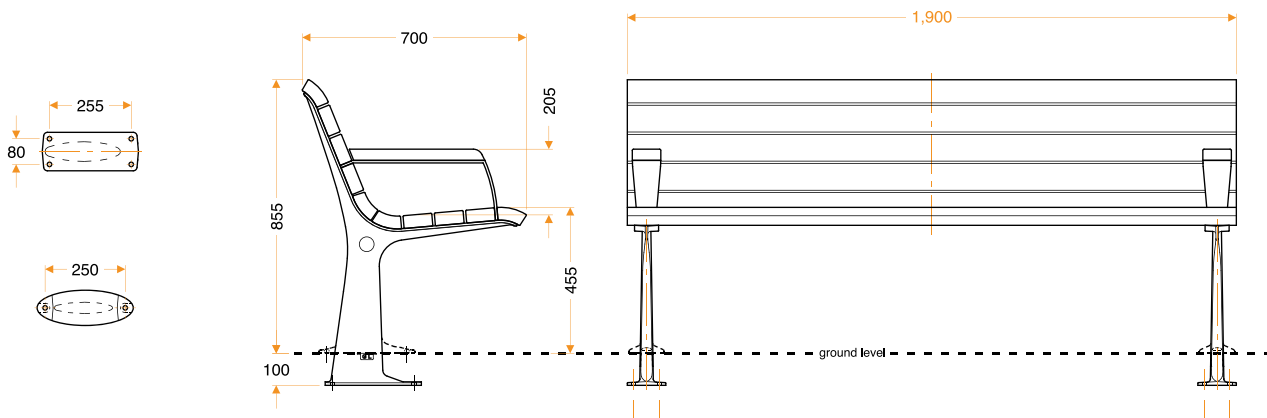

### Specifications:

- Timber and cast ductile iron seat with back support.
- Length 1900mm.
- Supports are manufactured from 10mm cast ductile iron with is more durable than cast iron.
- The ductile iron components are galvanised with polyester powder coat finish, see our colour options.
- Hardwood Timber slats are 90x40mm.
- Fixtures and fittings are stainless steel.

### Concrete Foundations:

Recommended concrete foundation  
2100 x 800 x 150 mm.

### Options Available:

- Colours
- Arm Rests
- Recycled composite timber
- Available in different lengths
- Supports can be root fixed or surface mounted

### Fitting:

Root Fixed: The root fixing is a base plate 100mm underground level with 4 fixing points on each support

Surface Mounted: There are 2 fixing points on each support

### HC2025S Seat Specifications:

Length	1900 mm
Width	700 mm
Seating Height	450 mm
Overall Height	860 mm



**HARTECAST**  
Street Furniture

www.hartecast.com E: info@hartecast.com IRL T: +353 (0)51 424922 UK T: +44 (0)161 820 6906

