

HC3000S SEAT

SEAT RANGE



➤ **HC3000S 4 Seater**

➤ **HC3000S 3 Seater**

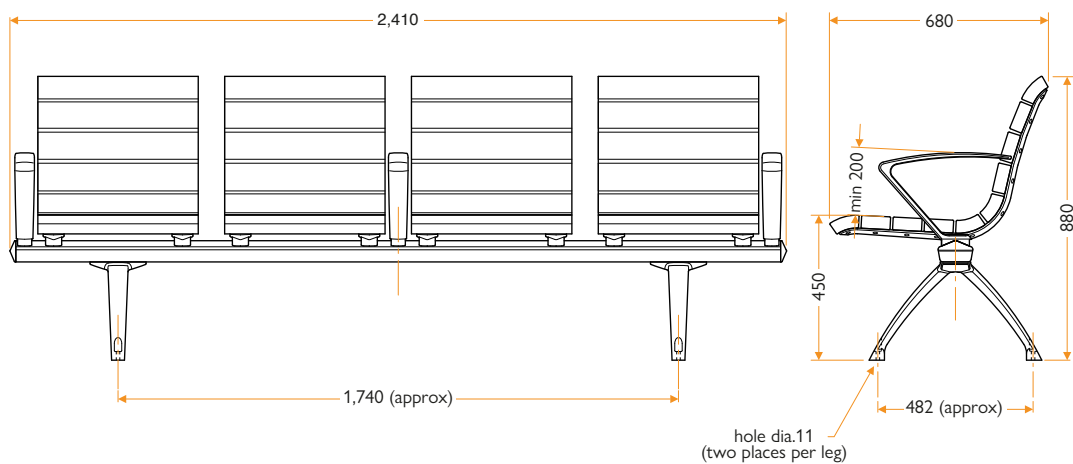

Specifications:

- Recycled Composite Timber, stainless steel and cast ductile iron seat with back support and dividing arms.
- Available in various lengths and configurations.
- Supports are manufactured from cast ductile iron with is more durable than cast iron.
- The ductile iron components are galvanised with polyester powder coat finish, see our colour options. ➤
- Frame is stainless steel powder coated.
- Recycled Composite Timber slats are 90x40mm.
- Arms are cast stainless steel.
- Various arm rest configurations available
- Fixtures and fittings are stainless steel.

Fitting:

Surface Mounted: There are 2 fixing points on each support.

Concrete Foundations:

Recommended concrete foundation
2600 x 800 x 150 mm.

Options Available:

- Colours.
- Also available in various lengths.
- Various arm configurations.

HC3000S Specifications:

Length	2410 mm
Width	680 mm
Seating Height	450 mm
Overall Height	880 mm



HARTECAST
Street Furniture