

HC2053 LITTER / RECYCLING BIN UNIT

LITTER BIN RANGE



HC2053 300L Bin

Specifications:

- Cast ductile iron large litter bin unit with 3 compartments.
- These compartments can be utilised for: litter, recycling or a combination of both.
- The compartments can be modified to suit specific requirements which make it a very versatile unit.
- 4 litter posting apertures which can be restricted to customer requirements.
- 300 litre capacity.
- Manufactured from 12 mm cast ductile iron.
- Dimensions 1080 x 1111 x 523 mm.
- Fully galvanised with polyester powder coat finish, see our colour options.
- Robust and anti-vandal hinging mechanism, using 16 mm stainless steel shaft on door.
- Heavy duty sealed plastic liners to prevent liquid leaking from bin.

Fitting:

There are 2 fixing points on the base for fitting to the ground by mean of anchoring bolts.

Concrete Foundations:

Recommended concrete foundation 1200 x 600 mm

Options Available:

- Town logos / plaques.
- Recycle logos.
- Opening restrictors.
- Galvanised steel liner or plastic liner.
- Colours.
- Ash tray.

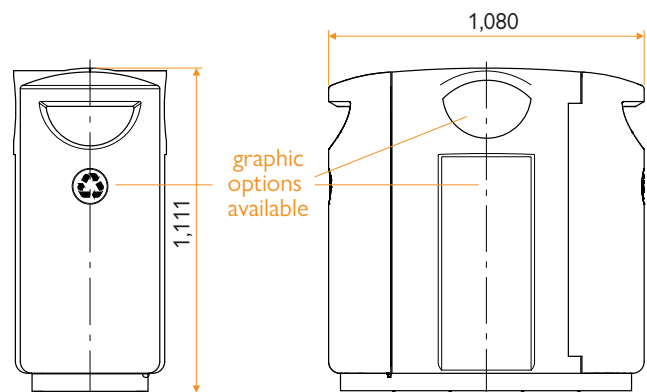
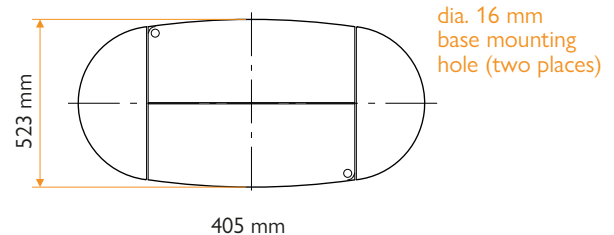

Specifications:

Height	1111 mm
Width	1080 mm
Depth	523 mm
Capacity	300 L



HARTECAST
Street Furniture