

HC2046S SEAT



SEAT RANGE



HC2046S Seat

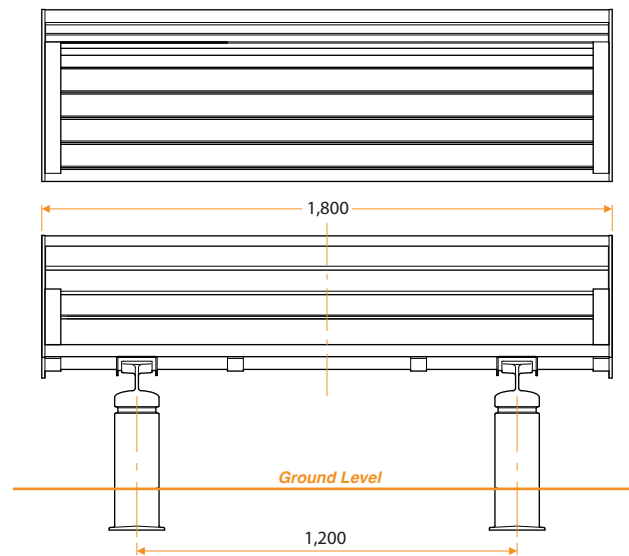
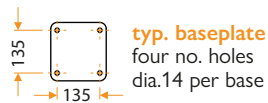
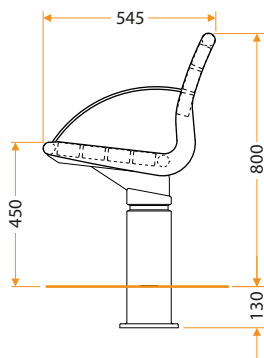

Specifications:

- Stainless steel, composite timber and cast ductile iron seat with back support and arm rests.
- Length 1800mm.
- Supports are manufactured from 10mm cast ductile iron which is more durable than cast iron.
- The ductile iron components are galvanised and polyester powder coated in our standard colours, please see our colour options. ➤
- The frame and armrests are 316 grade stainless steel with an electro-polished finish with recycled composite timber laths.
- Fixtures and fittings are stainless steel.
- Supports are root fixed.

Fitting:

Root Fixed: The root fixing is a base plate 130 mm underground level with 4 fixing points on each support.

Concrete Foundations:

Recommended concrete foundation 2000 x 800 x 150 mm.

Options Available:

- Laths are also available in timber as an alternative to composite timber. Timber is 70 x 40 mm FSC approved mahogany treated with a protective wood stain coating.
- Colours.
- Available in a Bench version without back support see HC2046B Bench. ➤

Specifications:

Length	1800 mm
Width	545 mm
Seating Height	450 mm
Overall Height	800 mm



HARTECAST
Street Furniture