

# HC2035S SEAT



➤ **HC2035S Seat** with 4 armrests

# SEAT RANGE



➤ **HC2035S** Standard Seat with 2 arm rests

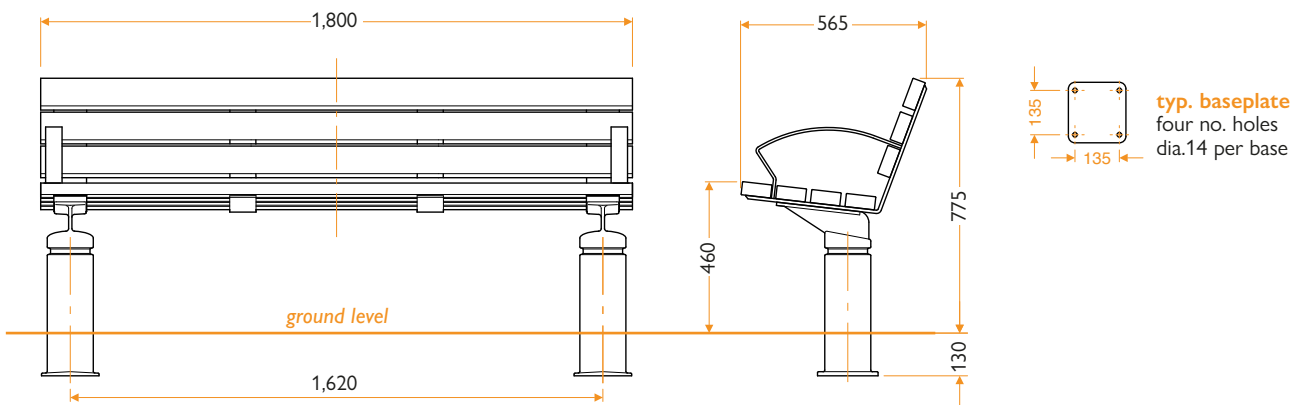

### Specifications:

- Timber and cast ductile iron seat with stainless steel frame complete with back support and side arm rests.
- Length 1800 mm.
- Supports are manufactured from 10 mm cast ductile iron which is more durable than cast iron.
- Armrests are manufactured from stainless steel.
- The ductile iron components are galvanised with polyester powder coat finish, see our colour options. ➤
- Fixtures and fittings are stainless steel.
- Timber slats are 70x40 and 90x40mm FSC approved mahogany.
- Root fixed.

### Fitting:

Root Fixed: The root fixing is a base plate 130 mm underground level with 4 fixing points on each support.

### Concrete Foundations:

Recommended concrete foundation 2000 x 800 x 150 mm.

### Options Available:

- Sikkins wood stain can be light oak or dark teak.
- Recycled composite timber.
- Colours.
- Extra dividing arm rests.

### Specifications:

Length	1800 mm
Width	565 mm
Seating Height	460 mm
Overall Height	775 mm



**HARTECAST**  
Street Furniture